



Door Solutions

ENTRANCE & INTERIOR



— Welcome home —
to HUME DOORS

www.doors.co.nz

April 2017

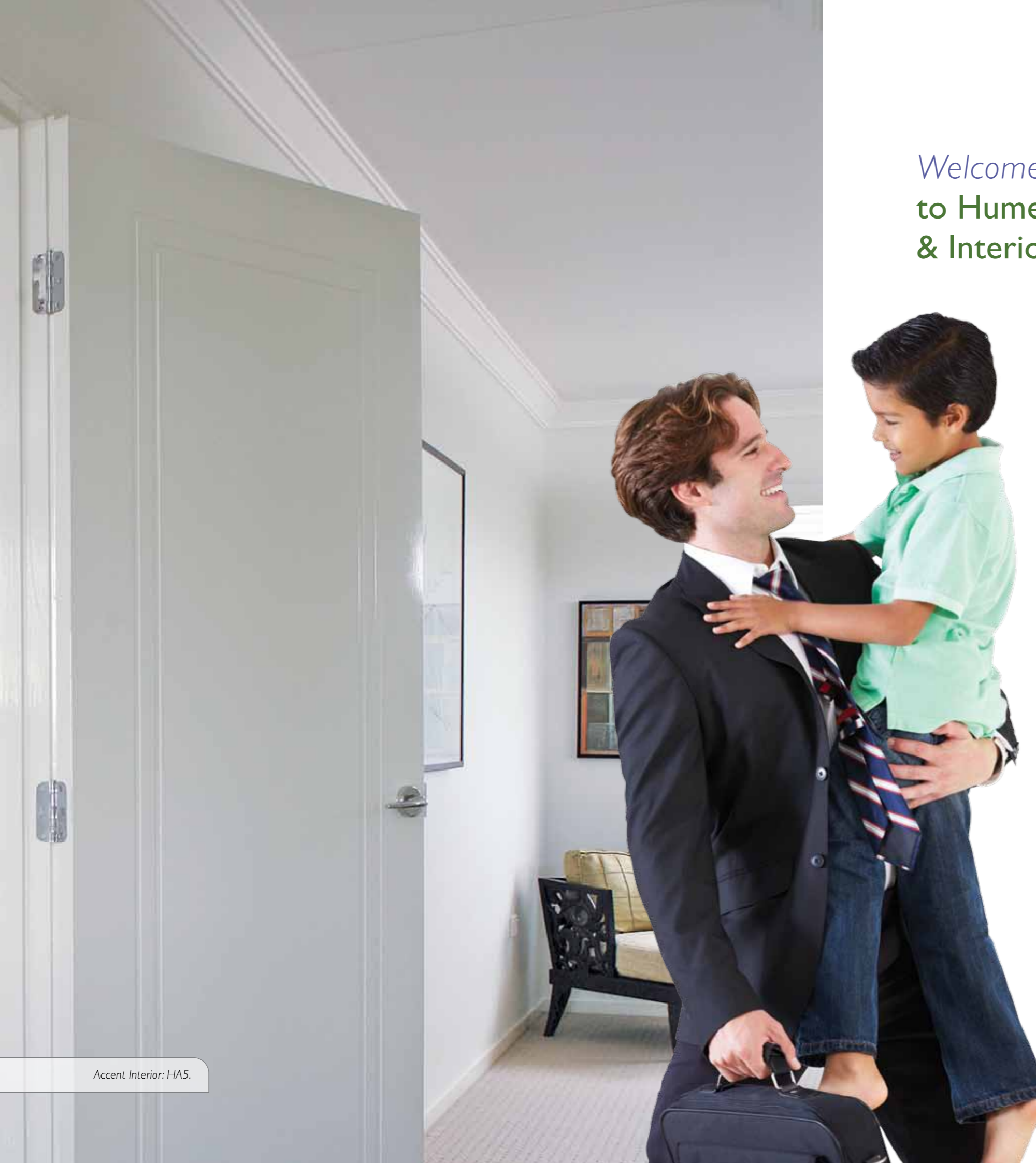

Welcome home to Hume Doors Entrance & Interior Door Solutions



For over 21 years Hume Doors & Timber (NZ) Ltd has supplied products to the New Zealand market and remains a strongly independent and 100% privately owned company.

Our range includes timber doors, fibreglass doors and an extensive range of associated product lines. We have operations in New Zealand, Australia and in Malaysia, with the latest manufacturing processes, modern equipment and with an eye on the environment, utilising timber from responsibly managed forests,

minimising waste and looking at better ways to conserve energy.

Hume Doors reputation for offering affordable, reliable and class leading products to the end consumer is beyond reproach.

From the largest commercial builders to the home handyman, the choice is Hume.



Our Values

- To innovate and make a difference in your home.
- To continue to build valued relationships with staff, suppliers and distributors.

Doors illustrated in this catalogue are constantly being improved and we reserve the right to change specifications without notice.

Doors are supplied unfinished and unglazed unless otherwise specified.

Colour variations may occur in actual glass design due to printing techniques.



Accent Interior: HAGI I.

Contents

ENTRANCE DOORS

Overhead Protection.....	4	Nexus Entrance.....	8
Entrance Specification Options:		Ultimo Entrance.....	9
Solicore Duracote.....	4	Lincoln Entrance.....	10
Solid Blockboard.....	4	Savoy Entrance.....	11
Linear Entrance.....	5	Regency Entrance.....	12
Newington Entrance.....	6	Vaucluse Entrance.....	13
Verve Entrance.....	7	Pioneer Entrance.....	14
		Glass Opening Entrance.....	15

GLAZING OPTIONS

Glass Types & Styles.....	16 / 17
---------------------------	---------

INTERIOR DOORS

Basic Interior Doors.....	18	Linear Interior.....	24
Accent Interior.....	19	Internal Specification Options:	
Moulded Panel Smooth Interior.....	20	Steel Inserts.....	28
Moulded Panel Woodgrain Interior.....	21	Evolution Cavity Units.....	29
Humecraft.....	22		
Sorrento Interior.....	23		

WARDROBE SOLUTIONS

SmartRobe Door System.....	26 / 27
----------------------------	---------

TIMBER

Timber Profiles.....	30
----------------------	----

GENERAL INFORMATION

Specials: Custom Made Interior.....	32	Care & Maintenance.....	34
Specials: Custom Made Entrance.....	33	Warranty / Guarantee.....	35

ENTRANCE

Overhead Protection

With New Zealand's climate extremes entrance doors will perform differently and timber doors are more susceptible to the elements than steel or aluminium.

Depending on your location and aspect the required overhead protection will vary. The formula below will assist in determining the size of overhead protection which will vary depending on home design and adjacent walls.

Formula | Overhead Protection: Sheltered Entry **A = 1/2 of B**

Dimension **C**: Subject to adjacent walls. Minimum width should be the same or more than the width of entry frame.

Note: Colour choice for your exterior door will also affect weathering. Dark colours absorb heat, accelerating door deterioration and potential for warping and bowing. **Dark colours will void the warranty.**

Paint with a light reflectance value (LRV) finish greater than 50 should be used on exterior doors.

White LRV: approx 95, black LRV: approx 5.

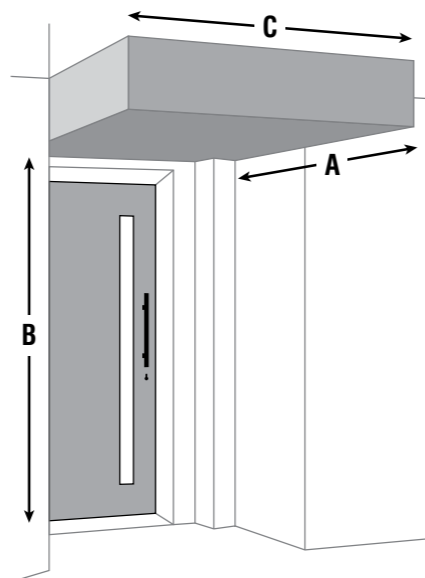

Solicore Duracote

Available with pre-primed tempered hardboard water resistant door faces.

- 3 Hinges recommended on all Solicore/Solid doors.
- NOTE: All entrance doors must be fully sealed/painted including top and bottom rails with paint prior to weather exposure. A minimum of two coats of sealer/undercoat followed by top coats.
- Entrance doors must be hung in weather protected areas.

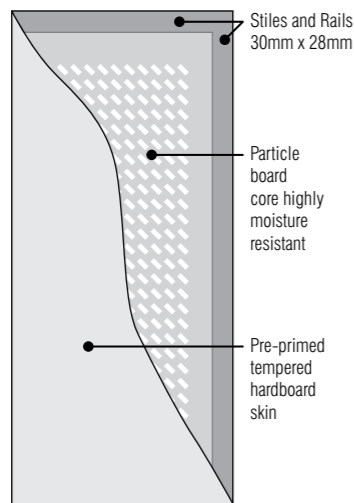

Solid Blockboard

Laminated timber core, tempered hardboard face (incorporating a moisture resistant glue).

- Door can be trimmed or cut down to any size including cut outs for air grills, glass opening.
- Square and rectangular cut outs only.
- **Not recommended for high gloss finish.**
- Entrance doors must be hung in weather protected areas.

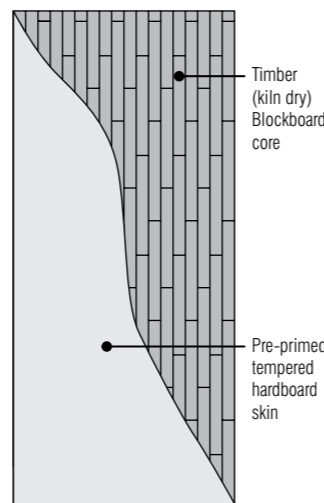

Solicore Duracote Sizes: (Stock doors will vary from branch to branch)		Solid Blockboard Sizes: (Stock doors will vary from branch to branch)	
1980 x 710 / 760 / 810 / 860 / 910 x 40mm		2400 x 1200 x 35mm	2100 x 920 x 35mm
Made to Order:		2100 x 1200 x 35mm or 40mm	2400 x 1200 x 40mm
1980 x 710 / 760 / 810 / 860 / 910 / 960 x 35mm		2100 x 920 x 40mm	1980 x 810 x 40mm

ENTRANCE

Linear

Striking, Unique & Stylish

Our designers have been inspired by modern European trends which has shaped the Linear range of doors. This unique range can showcase the natural beauty of timber with the innovation of contrasting grains or can be painted for that fresh stylish feel.

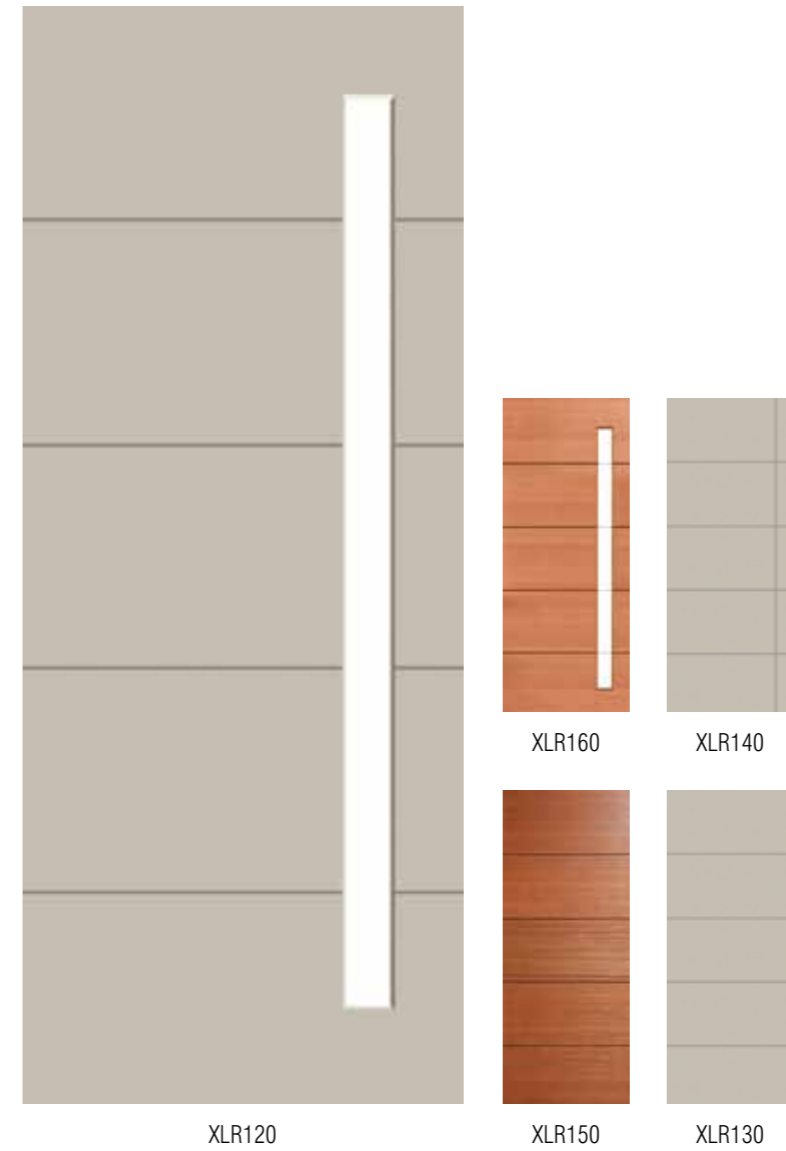

Linear Entrance: XLR160.

Linear | Specifications & Sizes (Sizes will vary from branch to branch)

- Standard Sizes: 1980 x 760 / 810 x 40mm
- Special Sizes: Up to 2400mm high – 1200mm wide
- Glazing Options: See Page 17
- Door Mass (For Standard Sizes): Approx 40–45kgs
- Skin Options: SPM or Duracote tempered hardboard

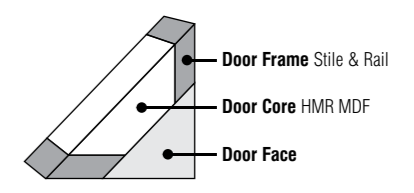

Entrance doors must be hung in weather protected areas. | When ordered in pairs, matched routing cannot be guaranteed.



ENTRANCE

Newington

Popular, Attractive & Versatile

The Newington range has a popularity that is a testament to its everlasting appeal and unmatched adaptability. The choices of dazzling designs, an array of glass options and matching sidelights (selected styles) provides limitless choices for you to create the look.

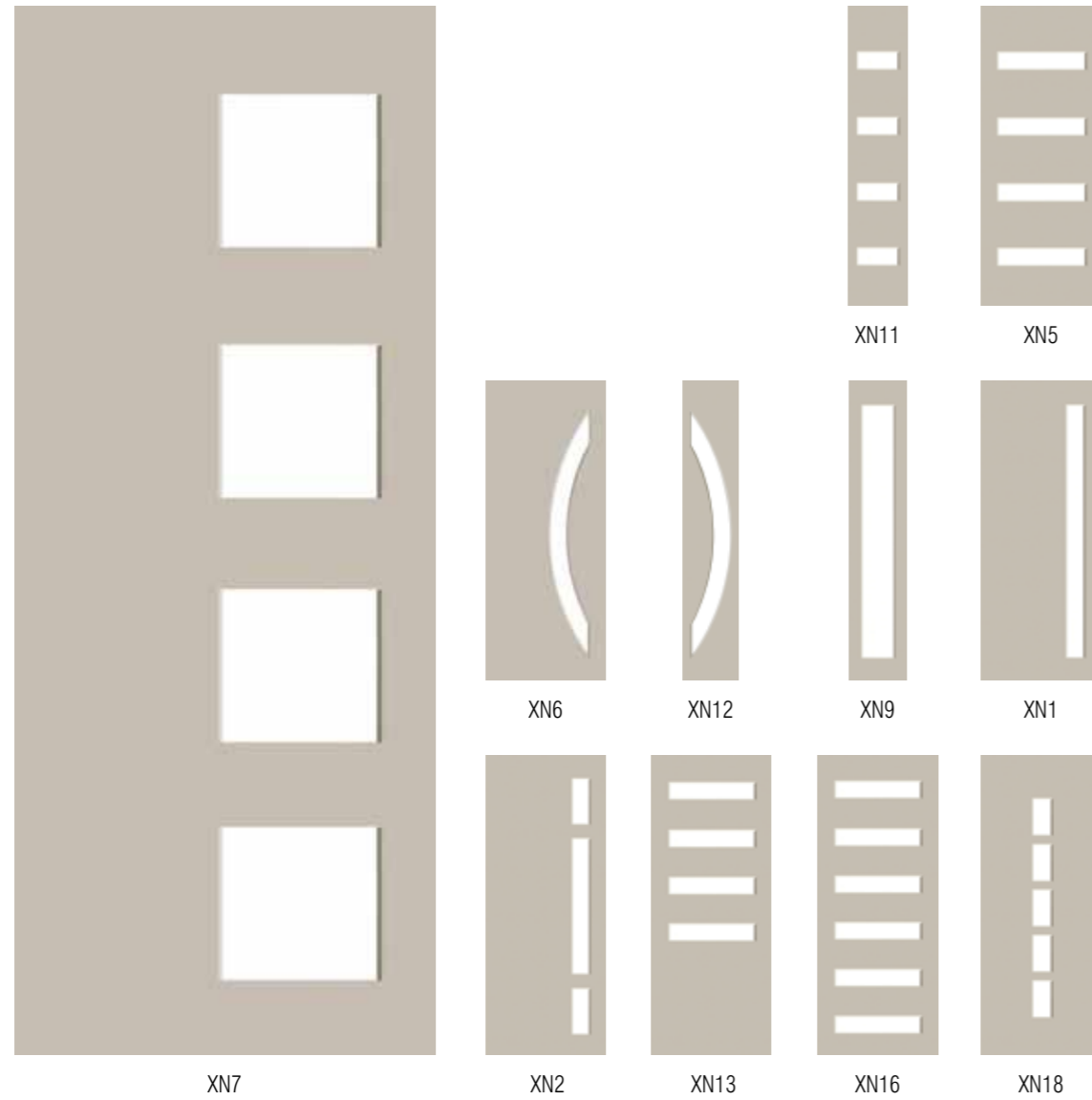

ENTRANCE

Verve

Sophisticated, Crisp & Neat

The Verve range has been designed with sleek slim glass panels, making for the finest in contemporary design. A selection of glass options creates endless possibilities in style.

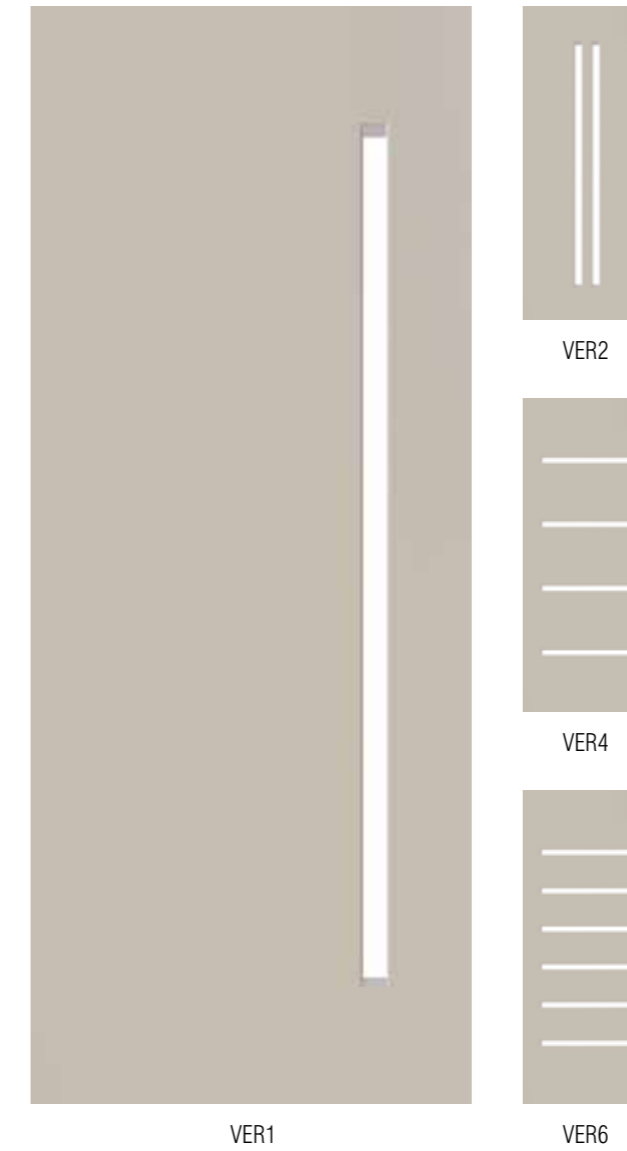

Newington Entrance: XN1 & XN9.



Verve Entrance: VER4.

Newington | Specifications & Sizes (Sizes will vary from branch to branch)

- | | |
|--|---|
| <ul style="list-style-type: none"> Standard Sizes: 1980 x 760 / 810 / 860 x 40mm Glazing Options: See Page 17 Skin Options: SPM / Duracote Tempered Hardboard | <ul style="list-style-type: none"> Special Sizes: Up to 2400mm high – 1200mm wide Door Mass (For Standard Sizes): Approx 40 – 45kgs |
|--|---|

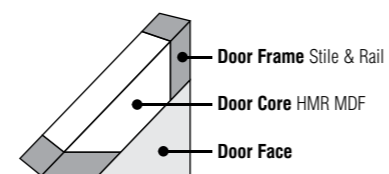

Entrance doors must be hung in weather protected areas.

Verve | Specifications & Sizes (Sizes will vary from branch to branch)

- | | |
|--|---|
| <ul style="list-style-type: none"> Standard Sizes: 1980 x 760 / 810 / 860 x 40mm Glazing Options: See Page 17 Skin Options: SPM / Duracote Tempered Hardboard | <ul style="list-style-type: none"> Special Sizes: Up to 2400mm high – 1200mm wide Door Mass (For Standard Sizes): Approx 40 – 45kgs |
|--|---|

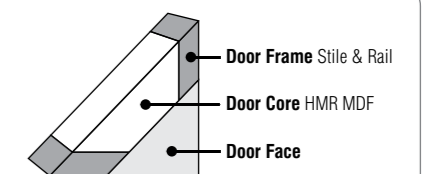

Entrance doors must be hung in weather protected areas.



ENTRANCE

Nexus

Subtle & Stylish

The Nexus range is designed with urban architecture in mind. These smart designs are the perfect link between the city scape and your home and the array of glass options provides limitless choices for you to create a seamless urban look.



ENTRANCE

Ultimo

Craftmanship & Simplicity

The Ultimo range is of the highest quality and our designers have produced a variety of styles to match architectural frontage.

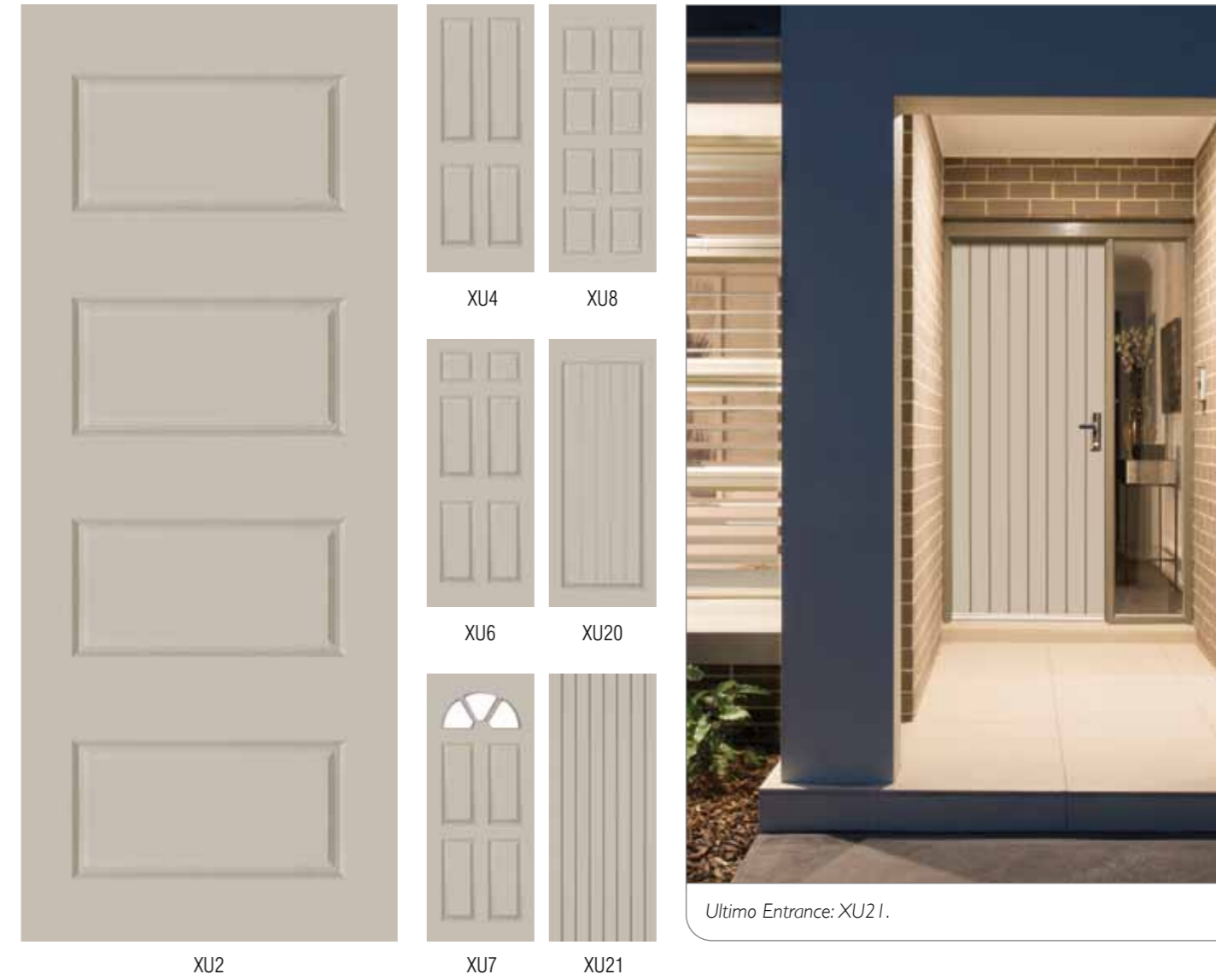

Nexus | Specifications & Sizes (Sizes will vary from branch to branch)

- | | |
|--|---|
| <ul style="list-style-type: none"> Standard Sizes: 1980 x 760 / 810 / 860 x 40mm Glazing Options: See Page 17 Skin Options: SPM / Duracote Tempered Hardboard | <ul style="list-style-type: none"> Special Sizes: Up to 2400mm high – 1200mm wide Door Mass (For Standard Sizes): Approx 40–45kgs |
|--|---|

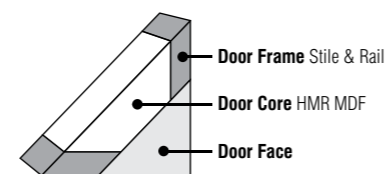

Entrance doors must be hung in weather protected areas.

Ultimo | Specifications & Sizes (Sizes will vary from branch to branch)

- | | |
|--|---|
| <ul style="list-style-type: none"> Standard Sizes: 1980 x 760 / 810 / 860 x 40mm Glazing Options: See Page 17 Skin Options: SPM / Duracote Tempered Hardboard | <ul style="list-style-type: none"> Special Sizes: Up to 2400mm high – 1200mm wide Door Mass (For Standard Sizes): Approx 40–45kgs |
|--|---|

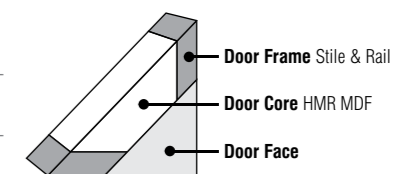

Entrance doors must be hung in weather protected areas.



ENTRANCE

Lincoln

Luxurious & Exclusive

The Lincoln range is the ideal match to traditional architecture or that executive fashioned residence. Crafted from select timbers this range features an engineered joinery construction system, which utilises traditional joinery methods as well as incorporating modern techniques.



ENTRANCE

Savoy

Stunningly eye catching

The Savoy Range is engineered using joinery construction techniques feature veneered laminated timber stiles and rails. Crafted from select timbers and available with a range of glass options to suit your style.



Lincoln | Specifications & Sizes (Sizes will vary from branch to branch)

- Standard Sizes: (No Special Sizes Available)
1980 x 810 / 860 x 40mm – Sidelight: 1980 x 400 x 40mm
- Glazing Options: See Page 17
- Skin Option: Meranti Veneer
- Door Mass (For Standard Sizes): Approx 40–45kgs

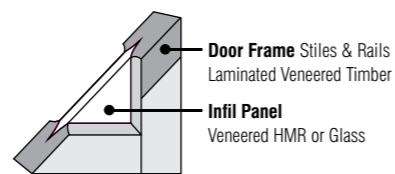

Entrance doors must be hung in weather protected areas | Natural wood variations (colour, texture, grain) are not considered as defects.

Savoy | Specifications & Sizes (Sizes will vary from branch to branch)

- Standard Sizes:
1980 x 810 / 860 x 40mm
- Skin Option: Meranti Veneer
- Door Mass (For Standard Sizes): Approx 40–45kgs
- Special Sizes:
Up to 2400mm high – 1200mm wide
- Glazing Options: See Page 17

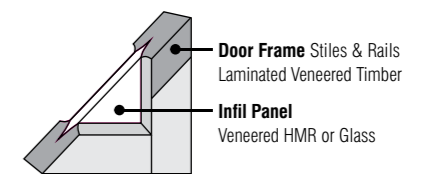

Entrance doors must be hung in weather protected areas | Natural wood variations (colour, texture, grain) are not considered as defects.



ENTRANCE

Regency

Supreme & Classic

The Regency range offers timeless designs with substantial timber mouldings to the exterior face plus deep routed designs to both door faces. Solid construction with a number of glazing options available, including triple glaze leadlight designs to complement any classically styled home.



XR1



XR2 XR5 XR6 XR4



Regency Entrance: XR4.

Regency | Specifications & Sizes (Sizes will vary from branch to branch)

- | | |
|--|--|
| <ul style="list-style-type: none"> Standard Sizes: 1980 x 810 / 860 x 40mm Glazing Options: See Page 17 Door Mass (For Standard Sizes): Approx 40–50kgs | <ul style="list-style-type: none"> Special Sizes: Up to 2400mm high – 1200mm wide Skin Option: Duracote Tempered Hardboard |
|--|--|

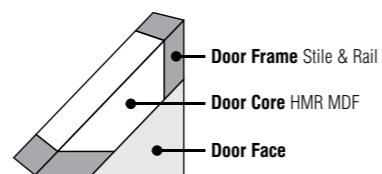

Entrance doors must be hung in weather protected areas.

ENTRANCE

Vaucluse

Premium & Superior by Design

Vaucluse doors have deep carved patterns on both sides of the door together with attractive moulding to the external side. A wide range of glass options are also available to match any décor.



XVP5

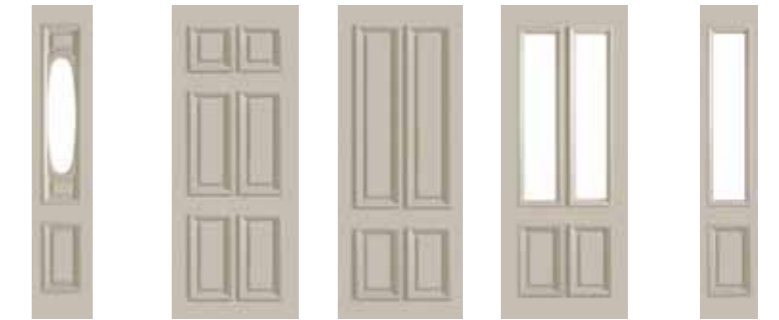

XVP6 XVP10 XVP11 XVP12 XVP13



XVP14



XVP20



Vaucluse Entrance: XVP14.

Vaucluse | Specifications & Sizes (Sizes will vary from branch to branch)

- | | |
|--|--|
| <ul style="list-style-type: none"> Standard Sizes: 1980 x 810 / 860 x 40mm Glazing Options: See Page 17 Door Mass (For Standard Sizes): Approx 40–50kgs | <ul style="list-style-type: none"> Special Sizes: Up to 2400mm high – 1200mm wide Skin Option: Duracote Tempered Hardboard |
|--|--|

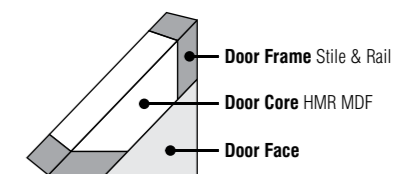

Entrance doors must be hung in weather protected areas.



ENTRANCE

Pioneer

Durable & Dependable

Well suited to exposed situations, the Pioneer door is designed to withstand tougher conditions. Fibreglass faces are durable and will not split.



PIO-4P



PIO-V



PIO-F



Pioneer Entrance: PIO-F.

ENTRANCE

Glass Opening

Simple & Functional

A classic back door design with three styles to choose from. Crafted from tempered hardboard and a range of glass options.



XF3



XF8



XF1



Glass Opening Entrance: XF8.

Pioneer | Specifications & Sizes (Sizes will vary from branch to branch)

- Standard Sizes: PIO-F / PIO-V: 1980 x 760 / 810 / 860 x 40mm
PIO4-P: 1980 x 810 / 860 x 40mm
- Skin Option: Fibreglass
- Door Mass (For Standard Sizes): Approx 40kgs

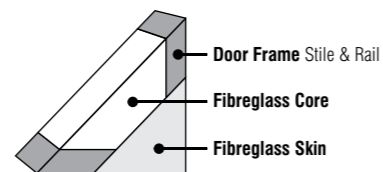

Entrance doors must be hung in weather protected areas.

Glass Opening | Specifications & Sizes (Sizes will vary from branch to branch)

- Standard Sizes: 1980 x 760 / 810 / 860 x 40mm
- Special Sizes: Up to 2400mm high – 1200mm wide
- Glazing Options: See Page 17
- Skin Option: Duracote Tempered Hardboard
- Door Mass (For Standard Sizes): Approx 45kgs

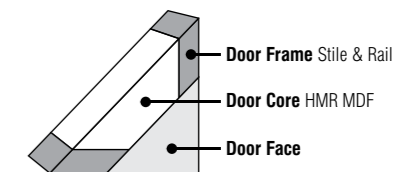

Entrance doors must be hung in weather protected areas.



Glazing

Glass Options Types & Styles



Newington Entrance: XN5, Glazed Clear.

Glass options for Entrance and Interior doors are detailed below, together with our exclusive Triple Glaze range (available for Regency and Vaocluse doors).

Glass colouring is as accurate as modern printing processes allow. Glass images shown are not to scale and some glass options require a 12 week lead time for production.

Triple Glaze

Our Triple Glaze option uses exclusive leadlight glass designs which are vacuum sealed with protected clear toughened glass each side.

	Page	Door Styles Applicable	Glass Options Available
Regency	12	XR1, XR2 : XR5, XR6 :	B E E
Vaocluse	13	XVP5, XVP6 : XVP12, XVP13, XVP14 :	A B C D

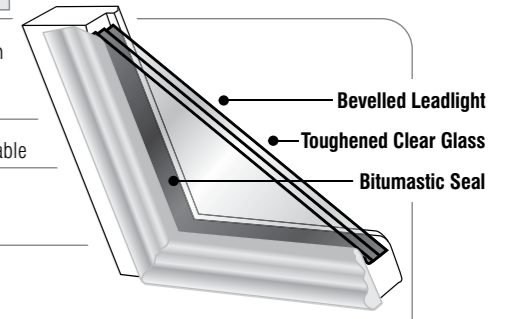

Entrance Doors

	Page	Door Styles Applicable	Glass Options Available
Linear	5	XLR120, XLR160	F G
Newington	6	XN1, XN2, XN5, XN11, XN6, XN12 : XN7, XN9, XN13, XN16 , XN16 :	F G F G
Verve	7	VER1, VER2, VER4, VER6	F G
Nexus	8	NEX10, NEX15, NEX20 : NEX30, NEX35 :	F G I J F G
Ultimo	9	XU7	F G N
Lincoln	10	XL3, XL4, XL6	F G H I J K L M
Savoy	11	XS11, XS28, XS45, XS24	F G
Regency	12	XR1, XR2	F G
Vaocluse	13	XVP12, XVP13, XVP14	F G H I J K L M
Glass Opening	15	XF1, XF3, XF8 (Toughened)	F G

Interior Doors

	Page	Door Styles Applicable	Glass Options Available
Accent	19	HAG13, HAG13D : HAG1-G, HAG1-GD, HAG4-G, HAG4-GD :	F G H I J K L M F G
Moulded Panel	20 & 21	BF28, ASCT-G, OAK-G, BF19	F G H I J K L M
Humecraft	22	HMC5	F G H I J K L M
Linear	24	HLR160, HLR120	F G



INTERIOR

Standard | Deluxe | Premium

Popular basic doors, suitable for all your interior needs. Available in Standard 3mm, Deluxe 4.75mm and Premium 6mm skins.



Core | Options & Specifications & Sizes

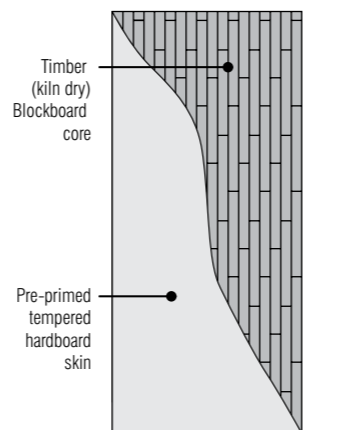
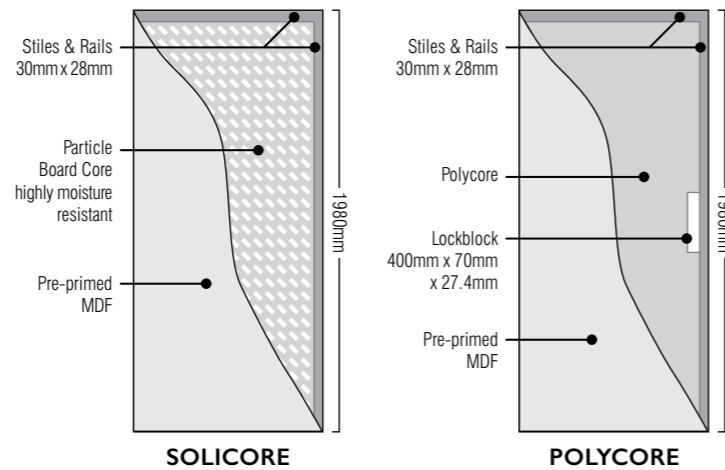
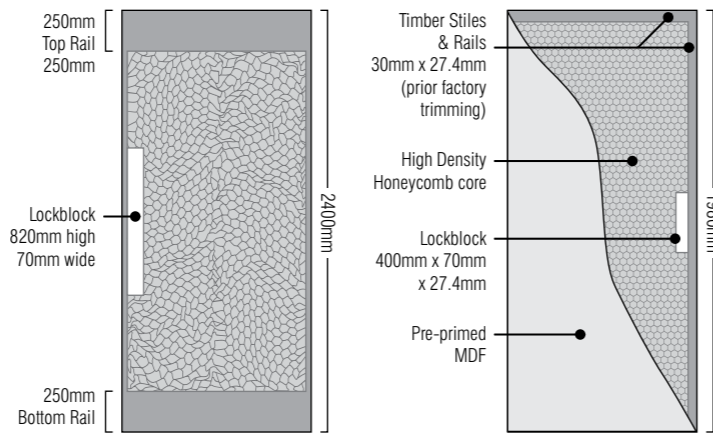

Basic Interior Doors | Specifications & Sizes*

<ul style="list-style-type: none"> Standard Heights: 1980 / 2200 / 2400mm Standard Widths: 410 / 460 / 510 / 560 / 610 / 660 / 710 / 760 / 810 / 860 / 910 x 35mm or 37mm SPM only available in 35mm 	<ul style="list-style-type: none"> Skin Options: Standard: 3mm Deluxe: 4.75mm Premium: 6mm
<ul style="list-style-type: none"> Special Sizes: 35mm thick, 2400mm high x 1200mm wide 37mm thick, 2700mm high x 1210mm wide 40mm thick doors also available 	<ul style="list-style-type: none"> Lockblocks: 35mm – One Side only 37mm – Both sides
<ul style="list-style-type: none"> Door Mass (Approximates Only, For Standard Sizes): Hollowcore: 15kg Polycore: 15kg Solicore: 25kg 	<ul style="list-style-type: none"> * Sizes will vary from branch to branch

INTERIOR

Accent

Elegant & Fashionable

The Accent internal range has trendy horizontal and vertical designs which create a modern straight forward style to suit an architectural theme. Available in Standard 35mm with 3mm skin or Deluxe 37mm with 4.75mm skin.

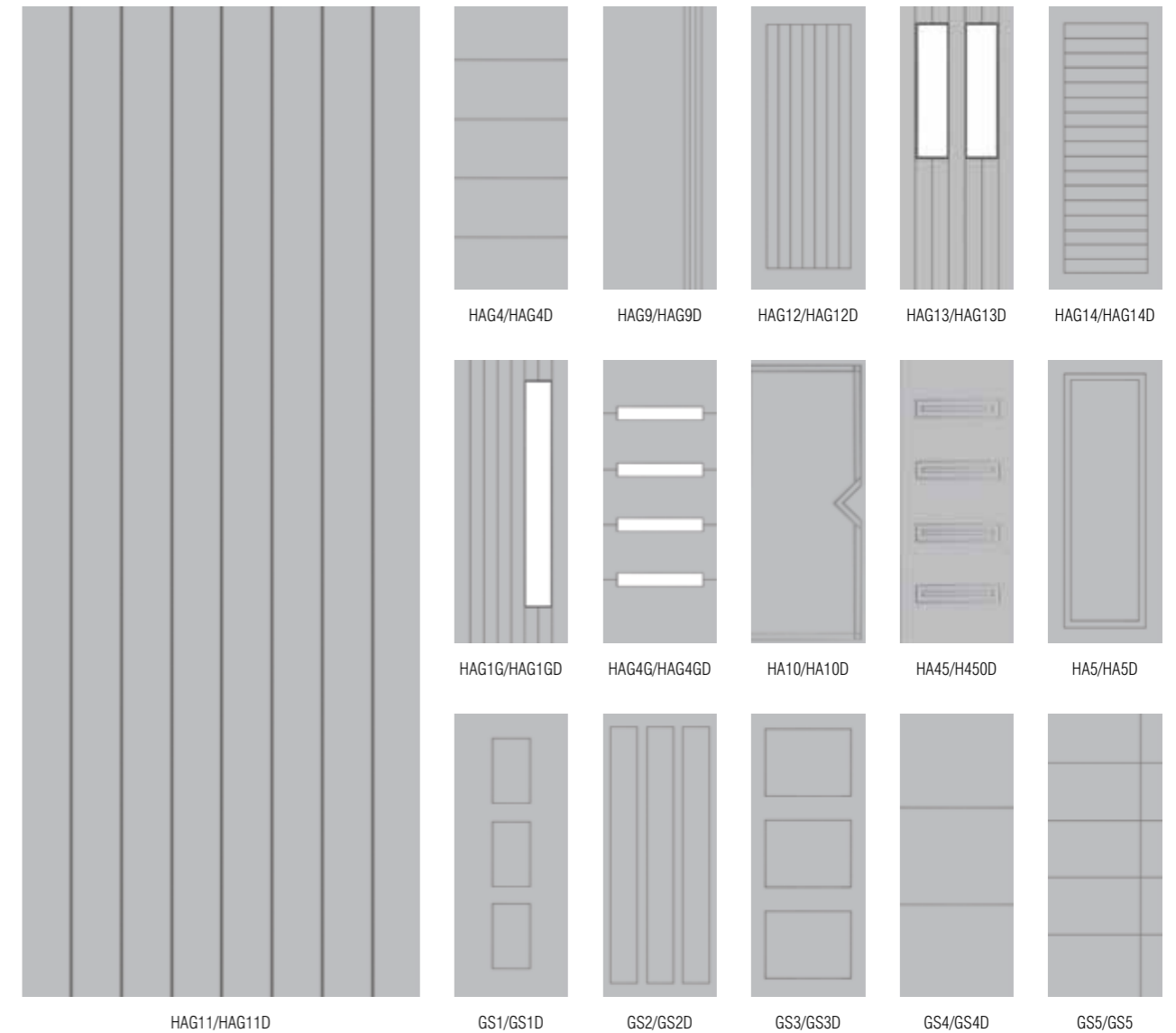

Accent | Specifications & Sizes* (Sizes will vary from branch to branch)

<ul style="list-style-type: none"> Standard Heights: 1980 / 2200 / 2400mm Standard Widths: 410 / 460 / 510 / 560 / 610 / 660 / 710 / 760 / 810 / 860 / 910 x 35mm or 37mm 	<ul style="list-style-type: none"> Special Sizes: 35mm thick: 2400 x 1200, 37mm thick: 2700mm x 1210mm, 40mm thick doors also available 	<ul style="list-style-type: none"> Core: Hollowcore, Polycore, Solicore. Open-tops are made from Solicore construction 						
<ul style="list-style-type: none"> Groove Type Profiles: <table border="0"> <tr> <td>Square 35 / 37mm</td> <td>V 37mm Deluxe</td> <td>U 35 / 37mm</td> </tr> <tr> <td></td> <td></td> <td></td> </tr> </table> 	Square 35 / 37mm	V 37mm Deluxe	U 35 / 37mm				<ul style="list-style-type: none"> Door Mass (Approximates Only, For Standard Sizes): Hollowcore: 15kg, Polycore: 15kg, Solicore: 25kg 	<ul style="list-style-type: none"> Glazing Options: HAG13 / HAG4G / HAG1G See Page 17 Lockblocks: 35mm – One Side only / 37mm – Both sides
Square 35 / 37mm	V 37mm Deluxe	U 35 / 37mm						

* When ordered in pairs, matched routing cannot be guaranteed.



INTERIOR

Moulded Panel | Smooth Skin | Traditional & Refreshing

These beautiful doors feature embossed smooth faces both sides in a range of refreshing designs plus the benefit of 2400mm high doors in the Ascot and Alpine models.

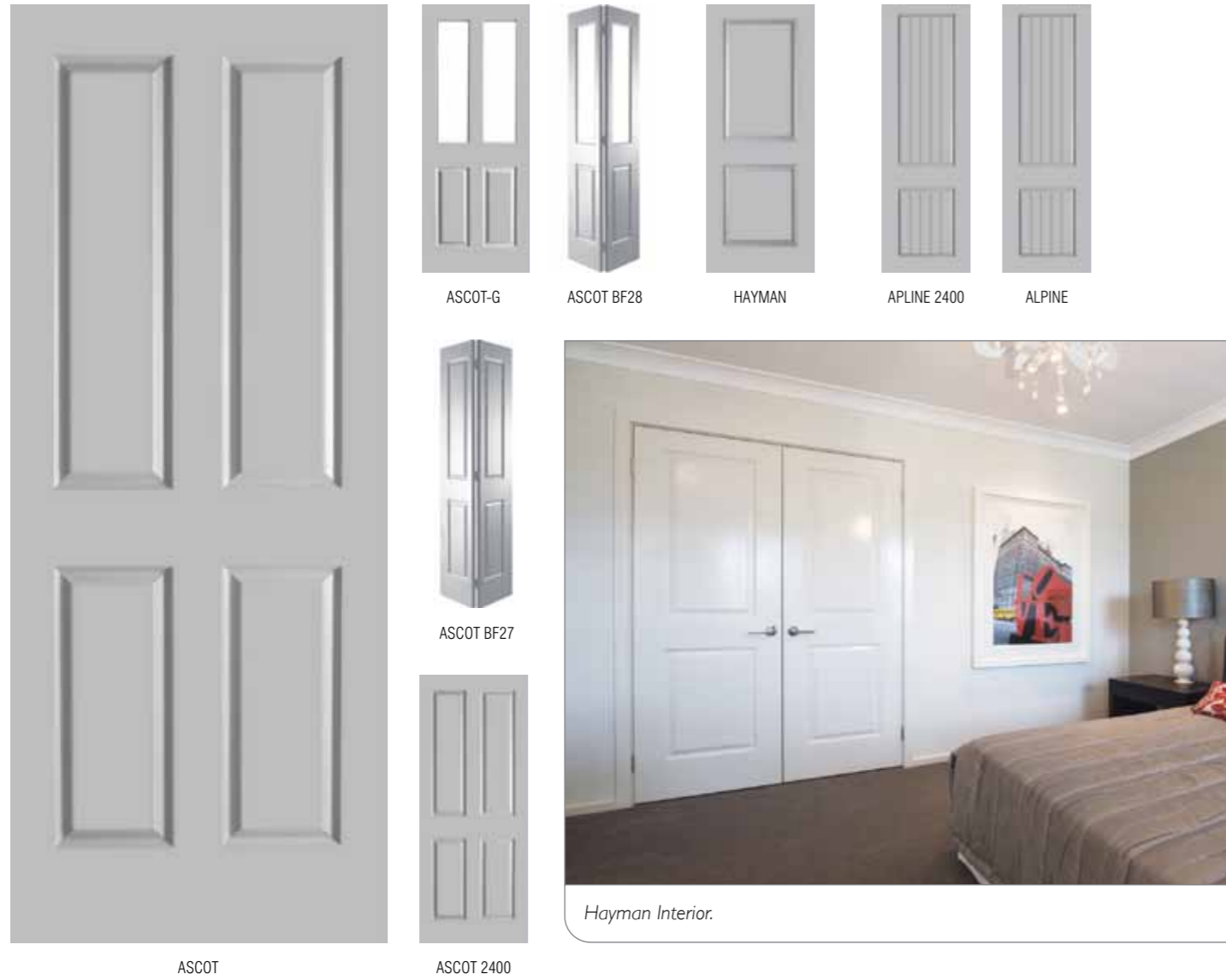

INTERIOR

Moulded Panel | Woodgrain | Classical & Timeless

These beautiful doors feature woodgrain embossed pre-primed faces to both sides and with so many different styles to choose from the Moulded Panel range has it all.

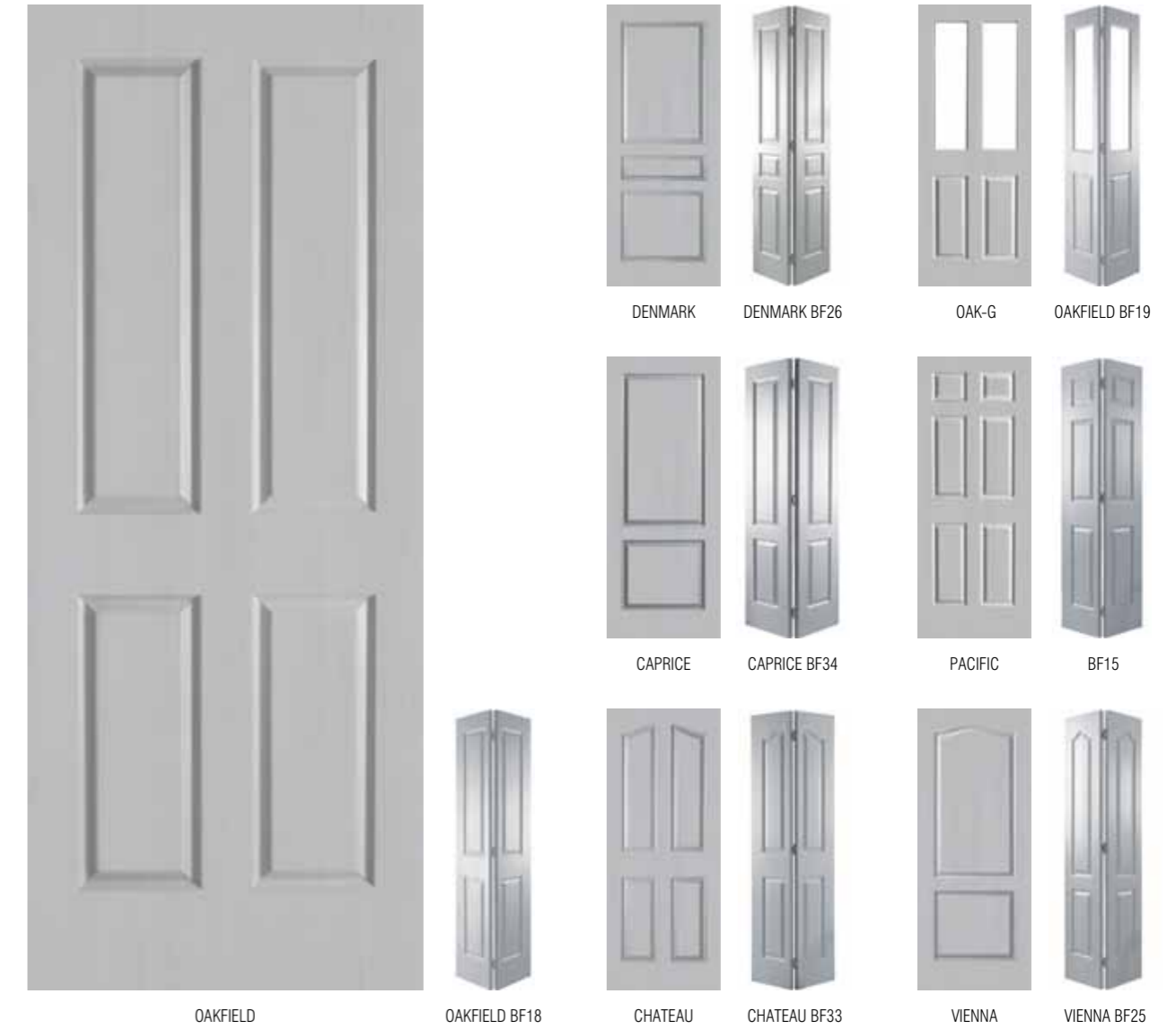

Moulded Panel Smooth | Specifications & Sizes (Sizes will vary from branch to branch)

• Standard Sizes: 1980 x 410 / 460 / 510 / 560 / 610 / 660 / 710 / 760 / 810 / 860 / 910 x 35mm

• Bifold Standard Sizes: 1980 x 610 / 660 / 710 / 760 / 810 x 35mm **only up to an 810mm**

• Special Sizes available

• Core: Hollowcore, Solicore
Not available with Steel Inserts

• Glazing Option:
Ascot-G, BF28 See Page 17

• Lockblocks: 35mm – Both sides

• Door Mass (For Standard Sizes): Approx 15–20kgs

• Skin: Smooth



Moulded Panel Woodgrain | Specifications & Sizes (Sizes will vary from branch to branch)

• Standard Sizes: 1980 x 410 / 460 / 510 / 560 / 610 / 660 / 710 / 760 / 810 / 860 / 910 x 35mm

• Bifold Standard Sizes: 1980 x 610 / 660 / 710 / 760 / 810 x 35mm **only up to an 810mm**

• Special Sizes available

• Core: Hollowcore, Solicore
Not available with Steel Inserts

• Glazing Option:
Oak-G, BF19 See Page 17

• Lockblocks: 35mm – Both sides

• Door Mass (For Standard Sizes): Approx 15–20kgs

• Skin: Woodgrain





INTERIOR

Humecraft

Discreet & Tasteful

Humecraft is a range of high quality internal solid doors featuring broad square carved designs on both sides.

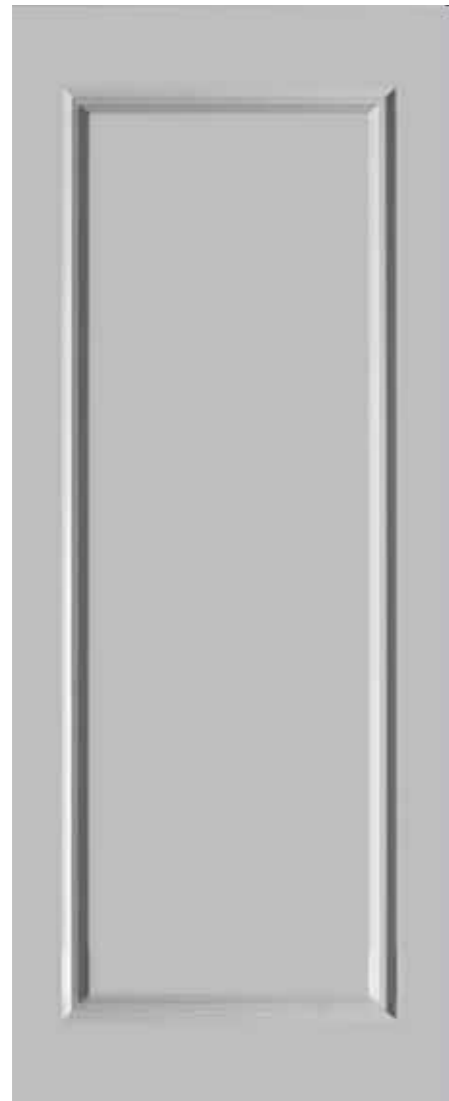

HMC1



HMC5



HMC7



HMC2



HMC4



Humecraft Interior: HMC1.

INTERIOR

Sorrento

Modern & Luxurious

The Sorrento brings that fresh contemporary feel to your home. The beautifully carved door designs feature on both sides and are produced on a 6mm pre-primed MDF door face.

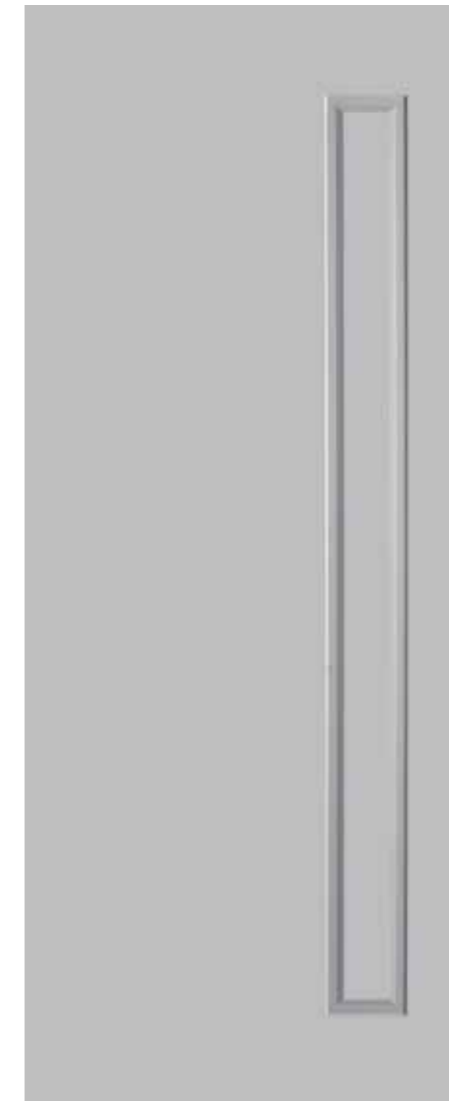

SOR1



SOR2



SOR5



SOR6



SOR7



SOR11



Sorrento Interior: SOR1.

Humecraft | Specifications & Sizes (Sizes will vary from branch to branch)

- Standard Sizes: 1980 x 410 / 460 / 510 / 560 / 610 / 660 / 710 / 760 / 810 / 860 / 910 x 35mm
- Special Sizes: Up to 2400mm high x 1200mm wide
- Core: MDF
- Glazing Option: HMC5 See Page 17
- Door Mass (For Standard Sizes): Approx 25kgs

Sorrento | Specifications & Sizes (Sizes will vary from branch to branch)

- Standard Sizes: 1980 x 410 / 460 / 510 / 560 / 610 / 660 / 710 / 760 / 810 / 860 / 910 x 35mm
- Special Sizes: Up to 2400mm high x 1200mm wide with an option of Steel Inserts
- Door Mass (For Standard Sizes): Approx 25kgs
- Glazing Options: NA
- Core: Hollowcore, MDF



INTERIOR

Interior Linear

Striking, Unique & Stylish

Our designers have been inspired by modern European trends which has shaped the Linear range of doors. This unique range can showcase the natural beauty of SPM with the innovation of contrasting grains or can be painted for a fresh style.



Linear Interior: HLR230.

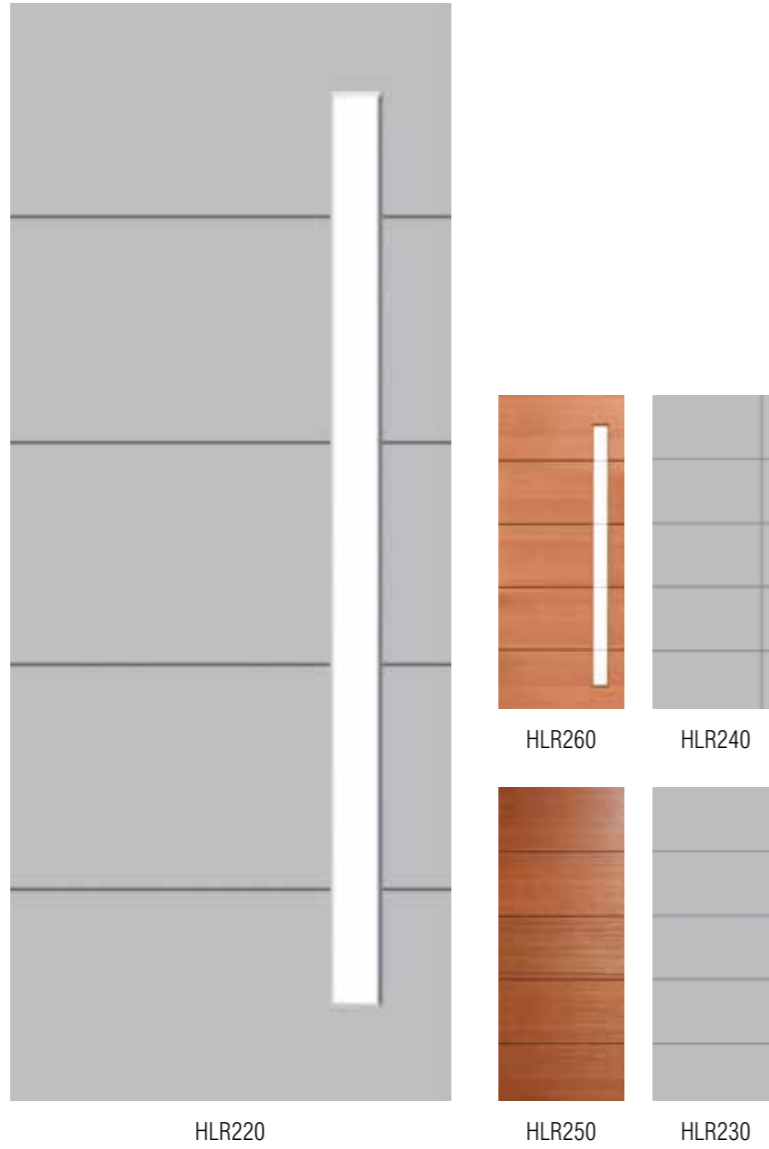

HLR220

HLR260

HLR240

HLR250

HLR230

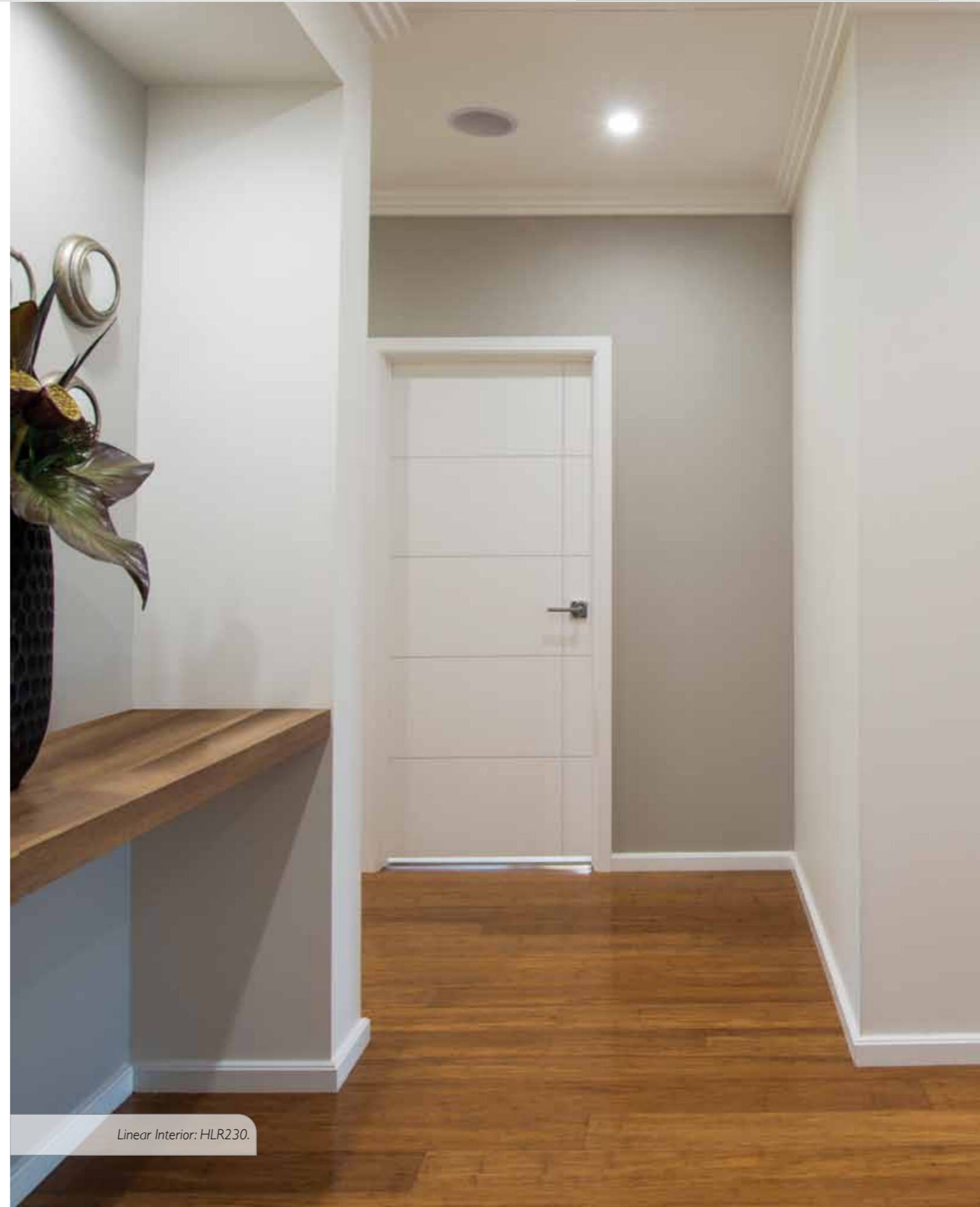

Linear Interior: HLR230.

Interior Linear | Specifications & Sizes (Sizes will vary from branch to branch)

• Standard Sizes: 1980 x 760 / 810 x 35mm	• Core: Opentop: MDF No Opentop: Hollowcore or MDF
• Special Sizes: Up to 2400mm high – 1200mm wide	• Glazing Options: See Page 17
• Door Mass (For Standard Sizes): Approx 15–35kgs	• Skin Options: SPM / Pre-primed MDF

When ordered in pairs, matched routing cannot be guaranteed.



INTERIOR

Smartrobe

Simplicity & Easy Fit

A sliding wardrobe door system, enabling you to carry through your chosen internal door theme.

Specifications & Sizes: (Sizes will vary from branch to branch)

Door Width	Track Size (Double Track Only)
2 x 410	800mm
2 x 460	900mm
2 x 510	1000mm
2 x 560	1100mm
2 x 610	1200mm
3 x 610	1800mm
4 x 610	2400mm
2 x 660	1300mm
3 x 660	1950mm
4 x 660	2600mm
2 x 710	1400mm
3 x 710	2100mm
4 x 710	2800mm
2 x 760	1500mm
3 x 760	2250mm
4 x 760	3000mm
2 x 810	1600mm
3 x 810	2400mm
4 x 810	3200mm
2 x 860	1700mm
3 x 860	2550mm
2 x 910	1800mm
3 x 910	2700mm

The Smartrobe Door System is compatible with the following Door Ranges:



BASIC DOORS
(refer to Page 18)



ACCENT RANGE
(refer to Page 19)



HUMECRAFT
(refer to Page 22)



MOULDED PANEL SMOOTH
(refer to Page 20)



MOULDED PANEL WOODGRAIN
(refer to Page 21)



SORRENTO
(refer to Page 23)

• Available in two, three, or four door units. (Only available in Double Track)

• The system comes with powder coated aluminium top and bottom tracks and doors with heavy duty nylon wheels encased in steel assemblies for smooth operation.

• Track available in white or silver.

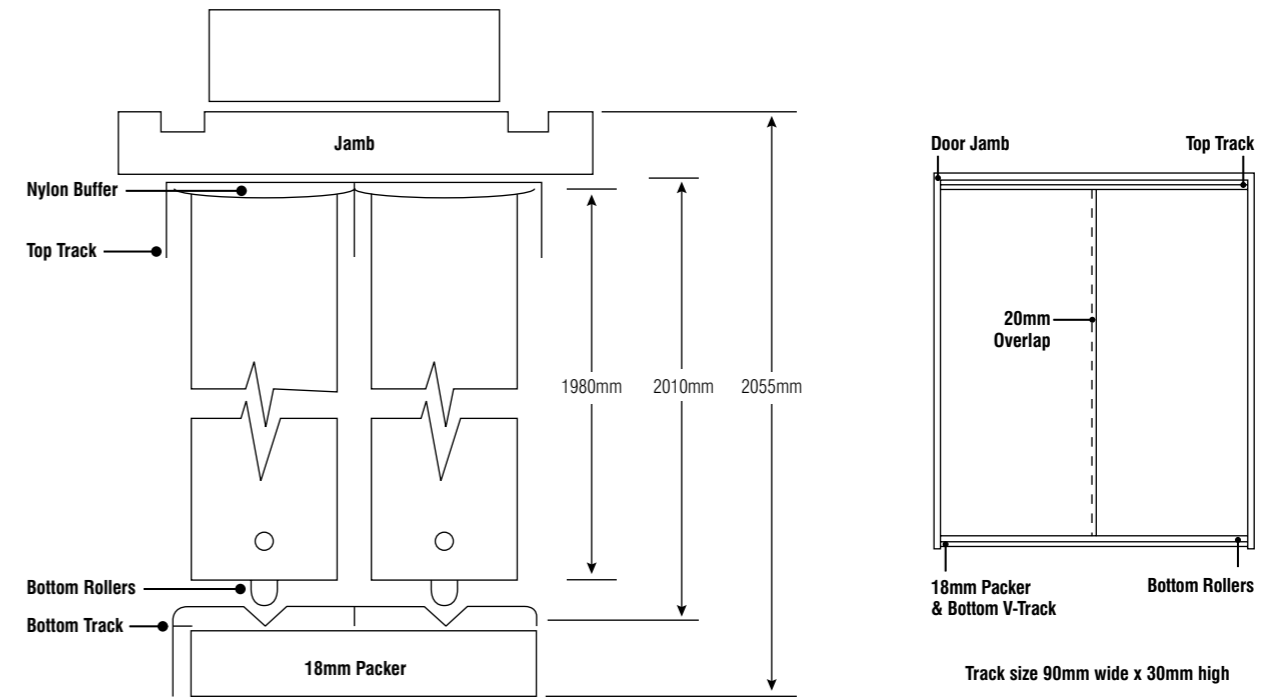
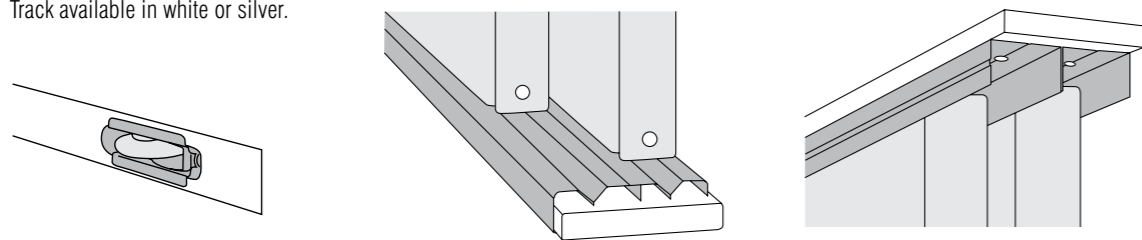

Smartrobe System: Full Mirror and Accent Interior: HAG4.



INTERIOR

Steel Inserts

Steel Strengthened — Tough & Sustainable

Where doors are more prone to bowing or twisting, use our double-sided engineer- designed Steel Inserts for extra strength to ensure that your door stays straight.

The Steel Insert options are available within our Deluxe Basic Interior and Accent Deluxe Door Ranges, and the 40mm thick Sorrento Range option.

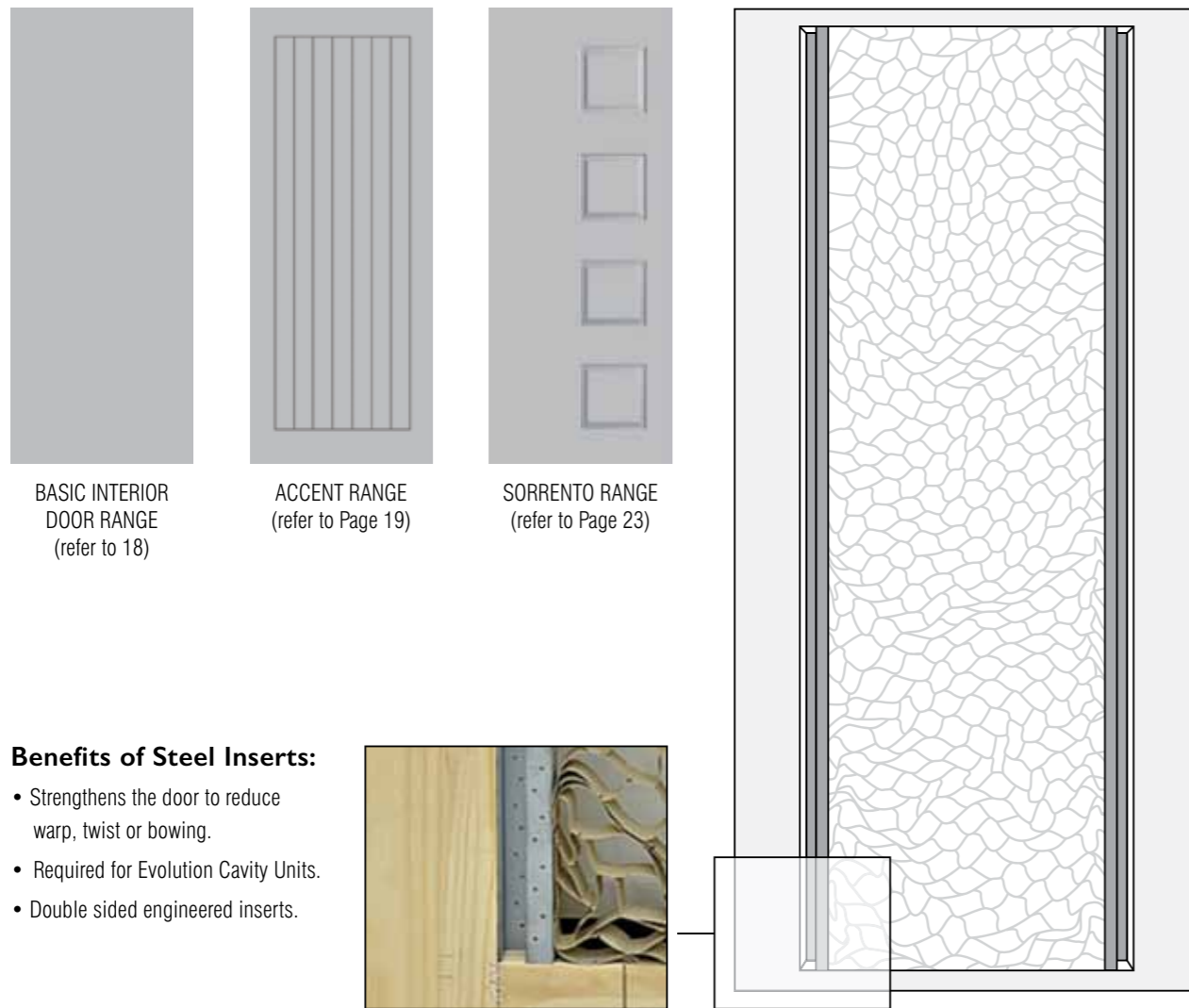

BASIC INTERIOR DOOR RANGE
(refer to 18)

ACCENT RANGE
(refer to Page 19)

SORRENTO RANGE
(refer to Page 23)

Benefits of Steel Inserts:

- Strengthens the door to reduce warp, twist or bowing.
- Required for Evolution Cavity Units.
- Double sided engineered inserts.



Steel Inserts | Specifications & Sizes (Sizes will vary from branch to branch)

- Standard Sizes: 1980 x 410 / 460 / 510 / 560 / 610 / 660 / 710 / 760 / 810 / 860 / 910 x 37mm
- Special Sizes: 37mm thick up to 2700mm high by 1210mm wide or 40mm thick up to 2400mm x 1200mm wide
- Door Mass (For Standard Sizes): Approx 35kgs
- Core: Hollowcore, Polycore, Solicore
- Skin Options: 4.75mm only

INTERIOR

Evolution Cavity Units

Concealed & Smooth Sliding

To utilise the space normally taken up by a hinged door we offer a sliding door option inside a wall called a Cavity Unit. The door simply slides smoothly into a pocket in the wall (90mm Stud Only).

Features & Benefits

- Available in standard sizes to suit 1980mm high doors and door widths of 910, 860, 810, 760, 710, 660 & 610mm.
- Closing jamba — supplied as standard.
- Heavy duty aluminium smooth running track.
- 4 wheel system — carries doors up to 70kg.
- No floor guides required, T-Guide supplied.
- Aluminium back post for strength and easy installation.
- Pine timber slats for easy fixing of wall linings.
- Aluminium bottom plate.
- For painting purposes, quick release base plate with wheel assembly, allows for easy removal (leaves wheels in track).
- Special size and double cavities are available.
- **For warranty cover, Steel Insert doors must be used for Cavity Units.**

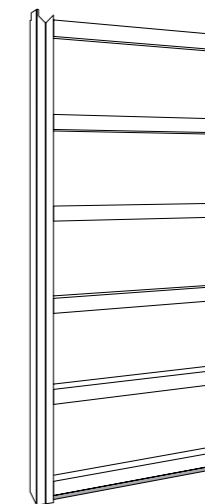

Evolution Grooved Jamb
(No architrave required)

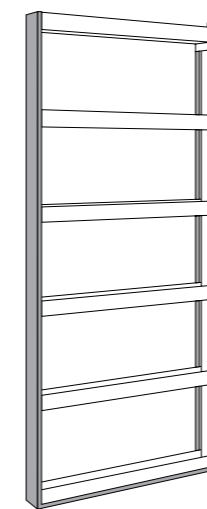

Evolution Flat Jamb
(Requires architrave for finished job)

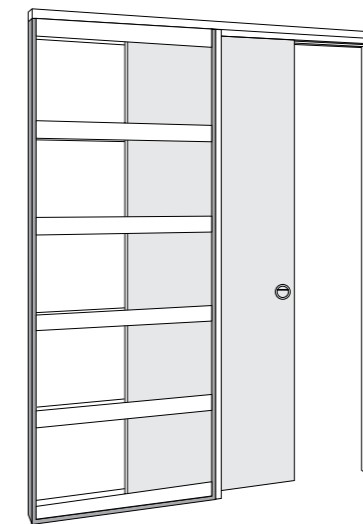

Evolution Cavity Unit



Track & Wheel Assembly

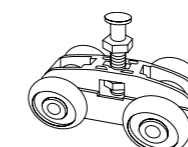

4 Wheel Assembly design reduces noise



PCM Basic in Evolution Cavity.

Evolution Cavity Unit | Sizes*

Door Width:	Door Height 1980mm:
610mm	2060mm x 1250mm
660mm	2060mm x 1350mm
710mm	2060mm x 1450mm
760mm	2060mm x 1550mm
810mm	2060mm x 1650mm
860mm	2060mm x 1750mm
910mm	2060mm x 1850mm

*Sizes will vary from branch to branch



INTERIOR

Timber Profiles

Manufactured by Hume Pine (NZ) Ltd

Door Jambs | Manufactured from finger jointed or clear untreated radiata pine.



Finger Joint: Available in North Island

Clears: Available in South Island

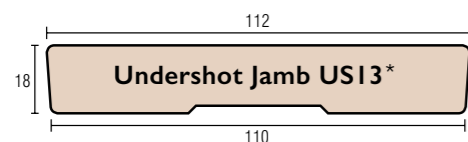

Finger Joint: Available in North Island

Clears: Available in South Island

Other Profiles available, made to order (minimum quantities apply)

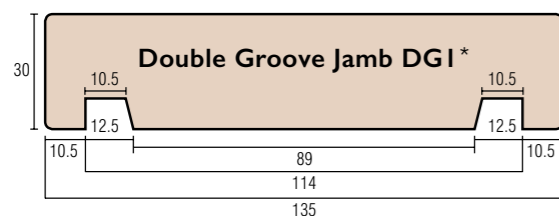

Finger Joint: Available in North Island

Clears: Available in South Island

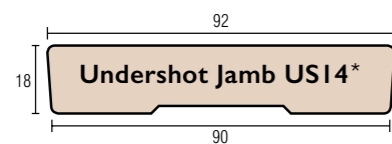

Finger Joint: Available in North Island

Clears: Available in South Island

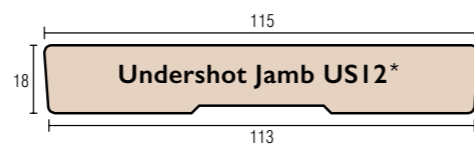

Finger Joint: Available in North Island

Clears: Available in South Island

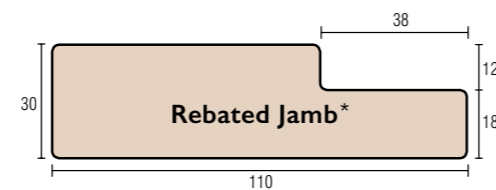
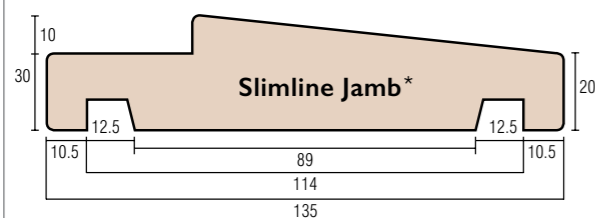

Order on Request.

*Profile illustrations are not to scale.



Moulded Panel Woodgrain Interior: Oakfield.



GENERAL

Specials Interior

Custom-Made Interior Doors

With our state of the art manufacturing factory we are able to manufacture special size and custom-made doors in our Auckland factory for your specific needs.

OPTIONS | Custom-Made Interior Doors*

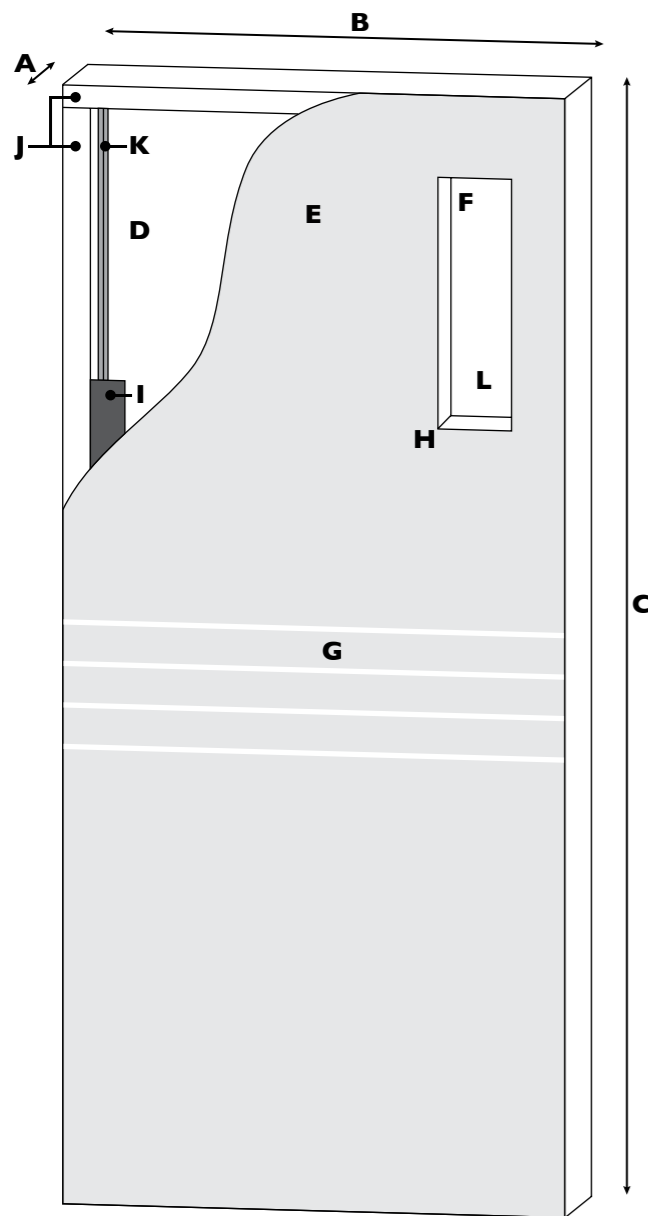

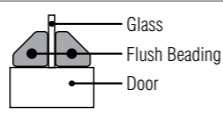
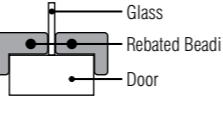
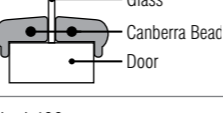
A Thickness	<ul style="list-style-type: none"> • 35mm, 37mm, 40mm, 45mm (Nominal)
B Width	<ul style="list-style-type: none"> • 35 / 40 / 45mm – 300mm up to 1200mm • 37mm – 300mm up to 1210mm • Add Steel Inserts for extra strength of over width doors
C Height	<ul style="list-style-type: none"> • 35 / 40 / 45mm – 300mm up to 2400mm • 37mm – 300mm up to 2700mm • Add Steel Inserts for extra strength of over height doors
D Core	<ul style="list-style-type: none"> • Polycore • Hollowcore • Solicore • Blockboard • MDF
E Skin	<ul style="list-style-type: none"> • Pre-primed MDF, 3mm, 4.75mm, 6mm • SPM (only available in 35 or 40mm thick doors) • Duracote Tempered Hardboard
F Opentop	We can cut a variety of squares and rectangles at different sizes
G Routing	<ul style="list-style-type: none"> • Square Groove: 4mm or 8mm • U Groove • V Groove (only available on 37 / 40 / 45mm thick doors) • Special Rout eg. Sorrento & Humecraft • Special Patterns
H Beading	<ul style="list-style-type: none"> • Unflush  • Rebated  • Canberra 
I Extra Lock Blocks	• Lengths Standard 400mm
J Thicker Stiles or Rail	
K Steel Inserts	
L Glazing	See Page 17

* All Special Orders may only be altered and/or cancelled within 24 hours from date of ordering and are non-returnable.

* Manufacturing capability will vary from branch to branch.

GENERAL

Specials Entrance

Custom-Made Entrance Doors

Some of the Interior and Entrance door custom-made options are detailed below and on page 32, or you can contact your nearest merchant or prehanger to discuss further.

OPTIONS | Custom-Made Entrance Doors*

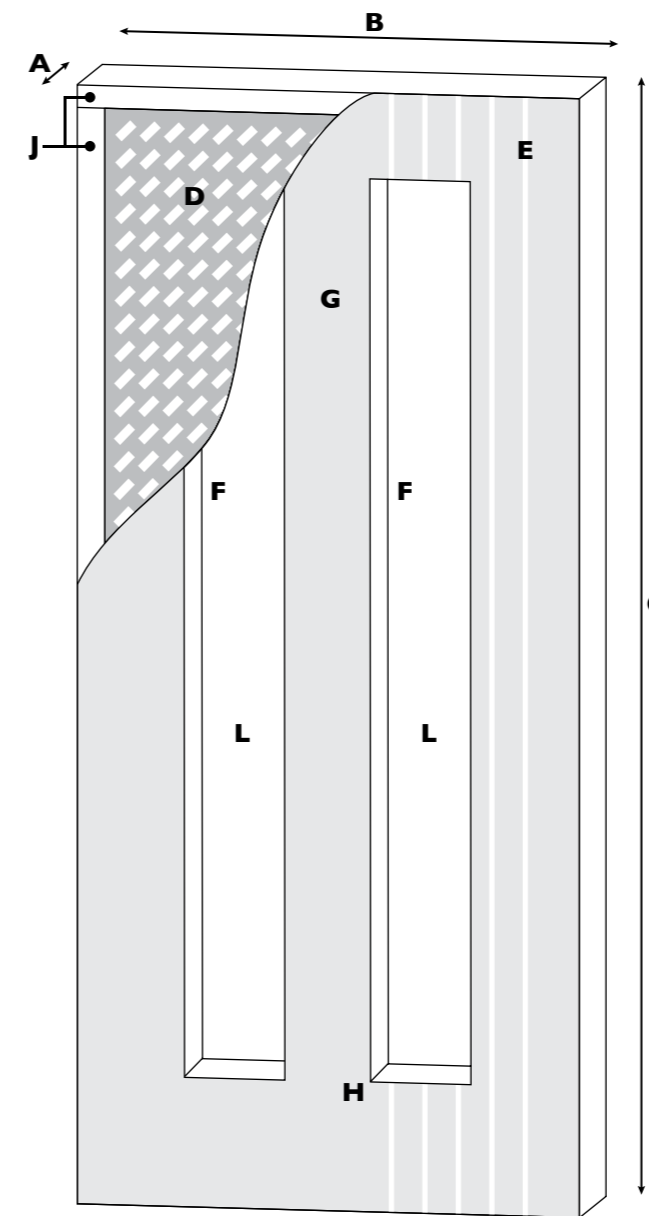

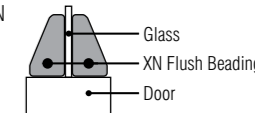
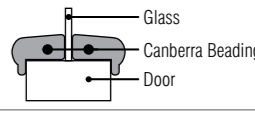
A Thickness	• 40mm, 45mm (Nominal)
B Width	• 40 / 45mm – 300mm up to 1200mm
C Height	• 40 / 45mm – 300mm up to 2400mm
D Core	<ul style="list-style-type: none"> • Solicore • Blockboard • MRMDF
E Skin	<ul style="list-style-type: none"> See Page 18 • SPM • Duracote Tempered Hardboard
F Opentop	We can cut a variety of squares and rectangles at different sizes for window openings.
G Routing	<ul style="list-style-type: none"> • Square Groove: 4mm or 8mm • U Groove • Special Rout • Special Patterns
H Beading	<ul style="list-style-type: none"> • Unflush XN  • Canberra 
J Thicker Stiles or Rail	Please enquire
L Glazing	See Page 17

* All Special Orders may only be altered and/or cancelled within 24 hours from date of ordering and are non-returnable.

* Manufacturing capability will vary from branch to branch.





GENERAL

Care & Maintenance

- After selecting and purchasing your Hume door, store flat in a dry, well ventilated area prior to installation.
- Your timber door may be affected by changes in temperature, moisture and location.
- Before fitment, all six door surfaces must be sealed initially then after installation painted, stained or clear finished with good quality products. Follow the paint manufacturer's instructions with the correct number of coatings on ALL surfaces.
- Light reflective colours are required for entrance doors to reduce the possibility of bowing, twisting or warping. **Dark colours will void Hume Guarantee** (see page 4 for light reflectance guide).
- Use the same colour on all six surfaces, different colours will cause doors to warp.
- All Entrance Doors require overhead protection (refer to page 4).
- Location and fitment of your door furniture depends on the door construction. Honeycomb core doors have a lock block located generally on the side with the Hume label, and door furniture should be fitted in this location. Solid doors may have door furniture installed at any selected height, either side of door.
- Door maintenance is necessary for long term performance and periodic inspections are recommended. At the first sign of deterioration, your door should be properly refinished, making sure that all bottom surfaces of the door receive proper resealing and painting.
- To clean your door, use a damp cloth. Do not hose or use chemicals or abrasives.



Moulded Panel Woodgrain Interior: Caprice.

GENERAL

Warranty / Guarantee

TERMS & CONDITIONS

Natural variations in the colour, texture or grain pattern of the wood are not considered defects. Doors must be accorded reasonable treatment by the purchaser and should be stored or hung in dry buildings and not in damp, moist or freshly plastered areas. The utility or structural strength must not be impaired in the fitting of the door, the application of hardware including cavity slider locks, or cutting and altering of the door for lights, louvres, panels or any special details.

A maximum of 3mm may be trimmed from any door edge, this must be done evenly.

Normal "show-through" of frame and skin components in door shall not be considered a defect. All entrance and solid core must be hinged with three (3) hinges.

Entrance doors must be hung in weather protected areas.

Doors and door systems that are installed in a fully exposed situation including opening out doors will not be warranted unless there is adequate overhead protection.

Immediately after fitting, and prior to hanging, the entire door, including the top and bottom edges, must receive a minimum of two coats of paint, or sealer to prevent absorption of moisture.

Semi-gloss or satin finishes are recommended for all doors to reduce "show-through". Exterior finishes applied strictly in accordance with manufacturer's instructions shall be used on entrance doors. Doors exposed to direct weather conditions should be finished with light colours to reduce the risk of heat distortion which may cause warping.

Dark colours will void guarantee.

Paint with a light reflectance value (LRV) finish greater than 50 should be used on exterior doors. White LRV: approx 95, black LRV: approx 5. Please consult your painter before proceeding. Both faces should have the same colour applied. Regular maintenance should be provided to prevent deterioration. Doors must be inspected upon arrival for visible defects and all claims based there-on must be filed within 24 hours.

The manufacturer agrees to repair or replace at its option, unfinished and in the form originally supplied and without charge, any door found to be defective within the meaning of the guarantee. The manufacturer will not be held responsible for additional charges of hanging, painting or other charges arising from the replacement of doors. Any such defects must be brought to the attention of the manufacturer when discovered and in any event within five years from the date of manufacturing.

The manufacturer is not liable to reimburse any purchaser for doors repaired or replaced without the prior written consent of the manufacturer to such repairs or replacement.

The manufacturer will not assume responsibility for doors which become defective because of failure to follow these conditions or for hazards of shipment or storage, after doors leave the control of the manufacturer.

ADVISORY NOTE

Considerable damage can occur during the delivery of doors particularly to rural areas.

"Special Packaging" is recommended (optional extra cost) in and attempt to prevent transit damage.

The Company is not responsible for any transit damage.

INTERPRETATION OF WARP

Warp shall be interpreted as meaning the cupping/bowing or twisting of doors. It refers to distortion within the door itself and not its relationship to the jambs or frame in which it is hung.

Warp exceeding 5mm for doors up to 2100mm x 920mm, 6mm for doors over 2100mm x 920mm and up to 2340mm x 920mm and 8mm for doors up to 2340mm x 1200mm shall be considered a defect.

Doors in excess of 2340mm high or 1200mm wide are not guaranteed against warp.

EXCLUSIONS

The guarantee against warp does not apply to the following:

- Doors with face veneers of different species.
- Doors that are improperly hung or do not swing freely.
- External flush doors which have been painted or stained dark colours, or different colours each face.

Experience has demonstrated that when warp occurs after doors have been delivered to storage or building sites, it is usually due to improper storage or adverse moisture conditions after hanging and not to faulty manufacture. The Company will accept no responsibility for doors when moisture content of the timber falls below 12% or exceeds 18%.

The Company will not accept responsibility for conditions wholly beyond its control.

However, the Company should be consulted promptly if excessive warping occurs to provide assistance in overcoming the difficulty.



Sorrento Interior: SOR5.

AUCKLAND

77 Plunket Avenue, Manukau,
Auckland, New Zealand

PO Box 76698, Manukau,
Auckland 2241, New Zealand

Phone: 09 277 4509

Email: sales@doors.co.nz

CHRISTCHURCH

26 Hammersmith Drive, Wigram,
Christchurch, New Zealand

PO Box 8946, Riccarton,
Christchurch 8440, New Zealand

Phone: 03 343 1555

Email: Christchurch@doors.co.nz

www.doors.co.nz